

■GB-72EC, 73EC, 102EC, 103EC, 122EC, 123EC, 123ED, 152EC, 153EC, GBU-123・1EC, 153・1EC, 123EC, 153EC(2Pは3Pの中極導体を除いたものです。)

単位：mm

表面形

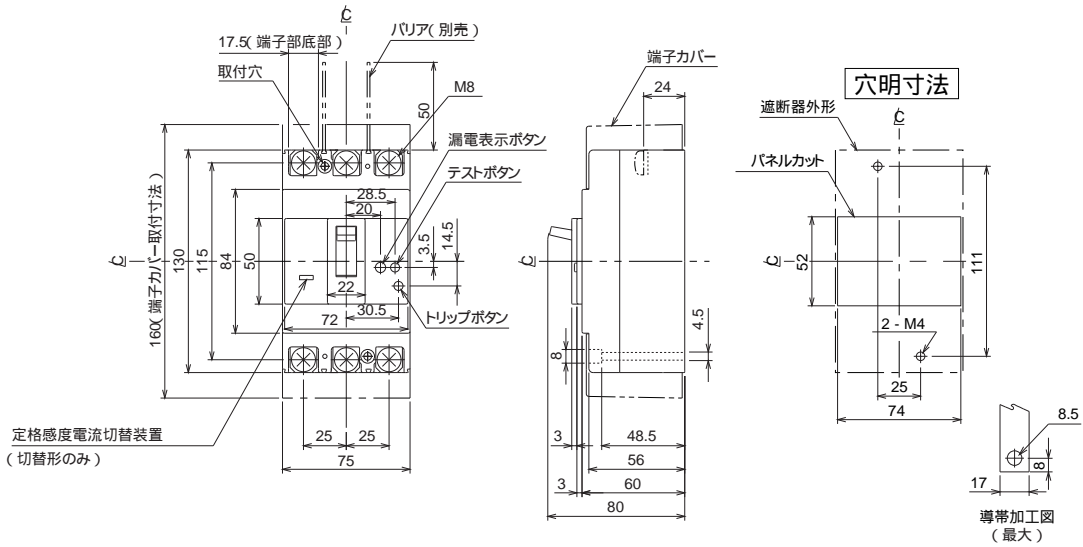

裏面形 SD)

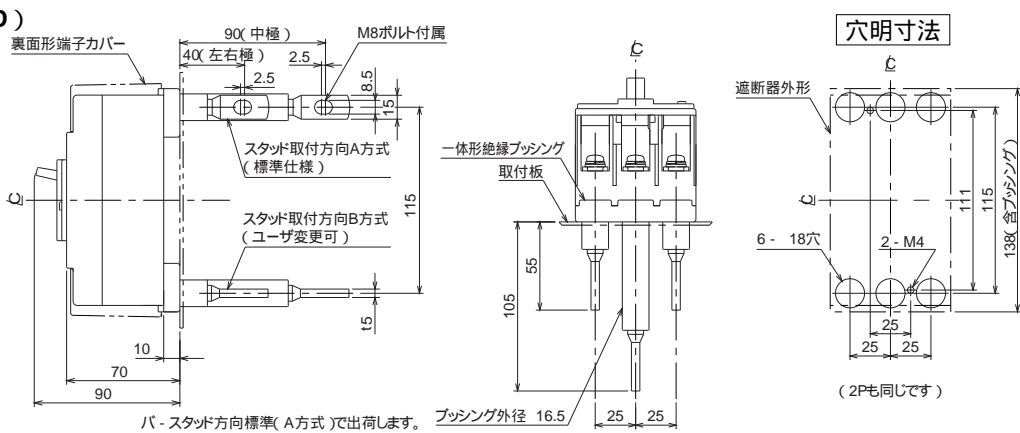

埋込形 FP)

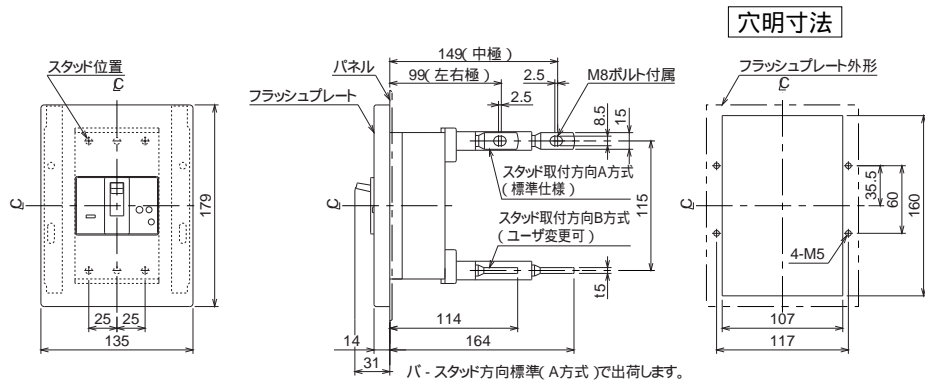

GB-72EC, GB-73EC

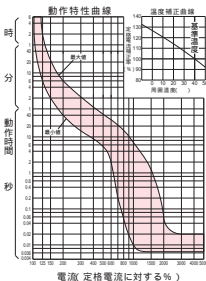

GB-102EC, GB-103EC

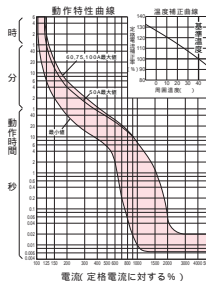

GB-122EC, GB-123EC, GB-123ED

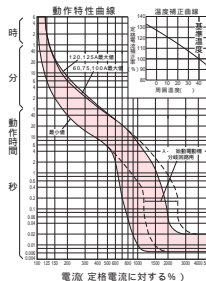

GB-152EC, GB-153EC

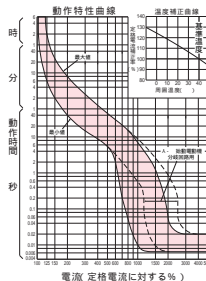

GBU-123・1EC, GBU-123EC

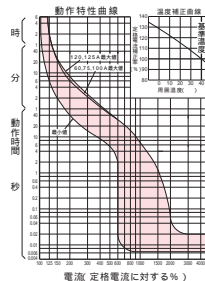

GBU-153・1EC, GBU-153EC

